



PROGETTO DEFINITIVO

Dettagli costruttivi / Sezioni tipo 1:20

Piano no. : **700.8.PDE/005**

Data : 15.11.2024 Dimensioni : 1'260x600
Scala: 1:20

Modifiche :
A : B : C :

Allestito : POF Controllato : MR Approvato : FB

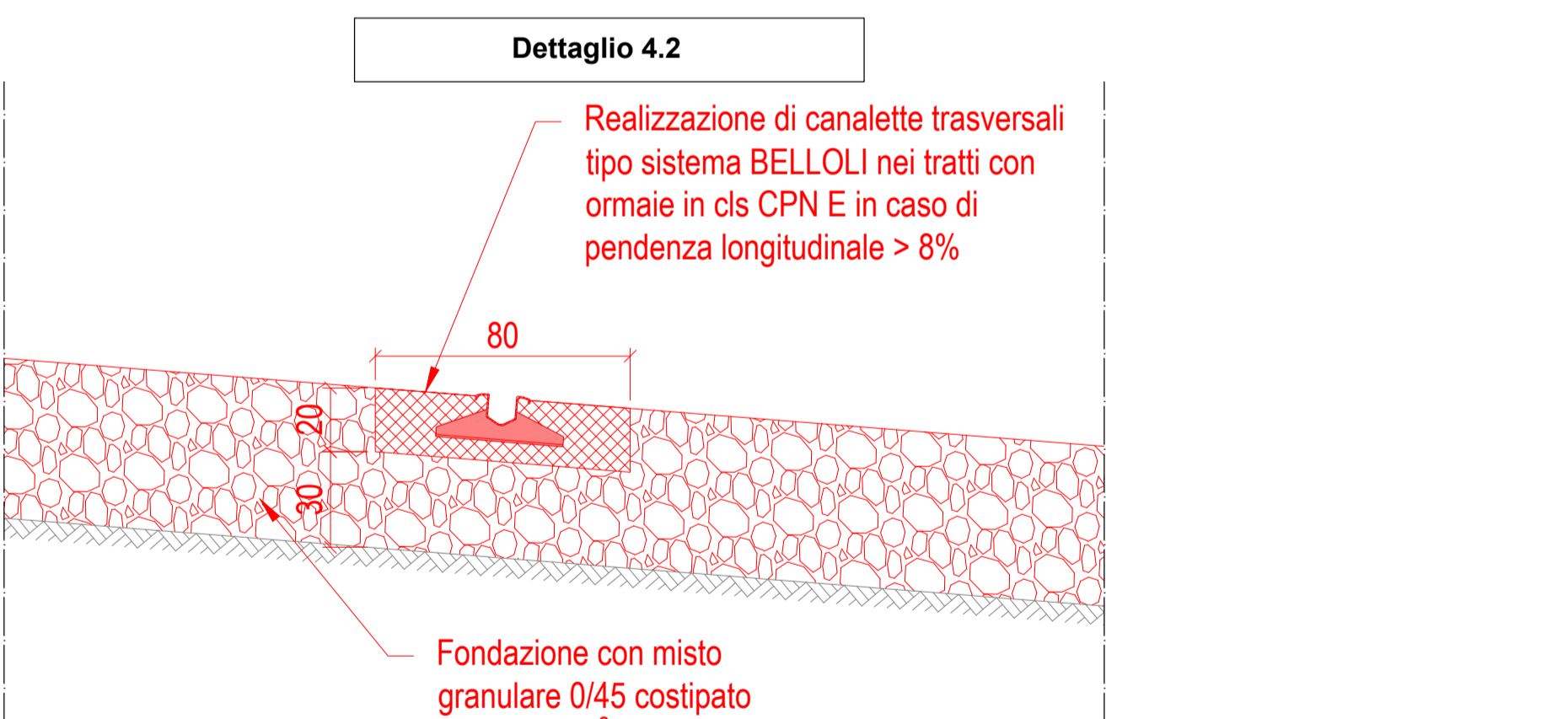
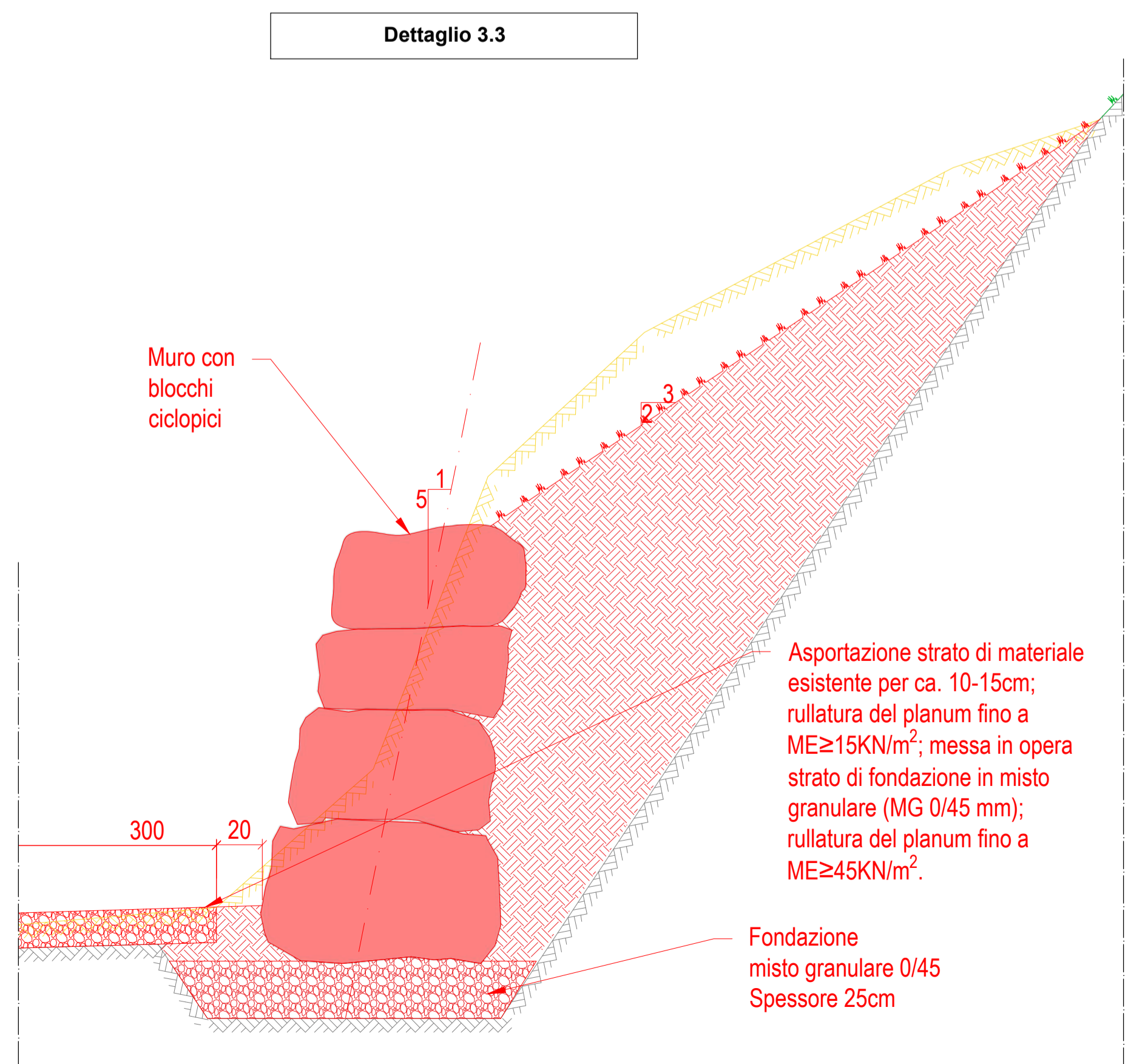
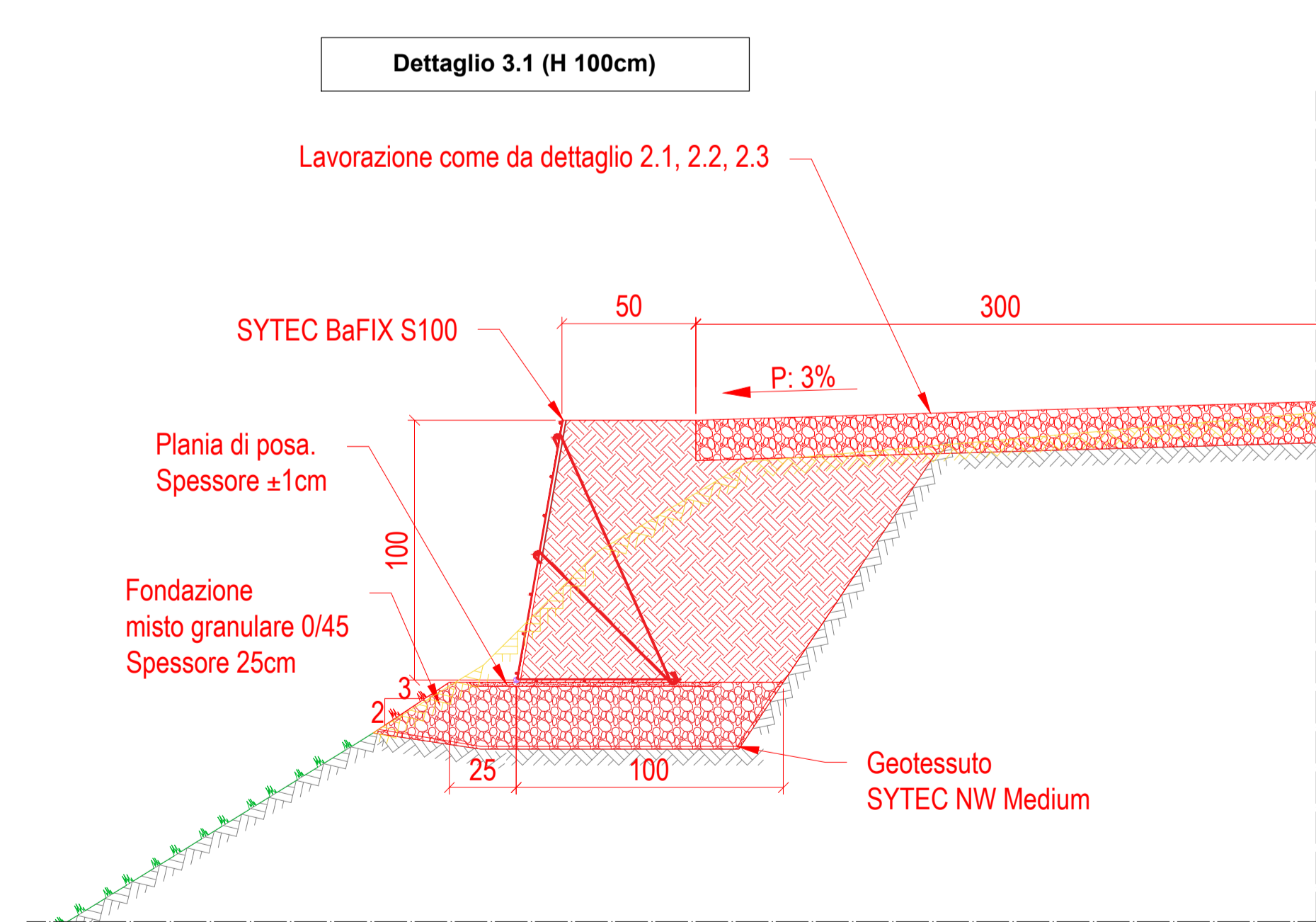
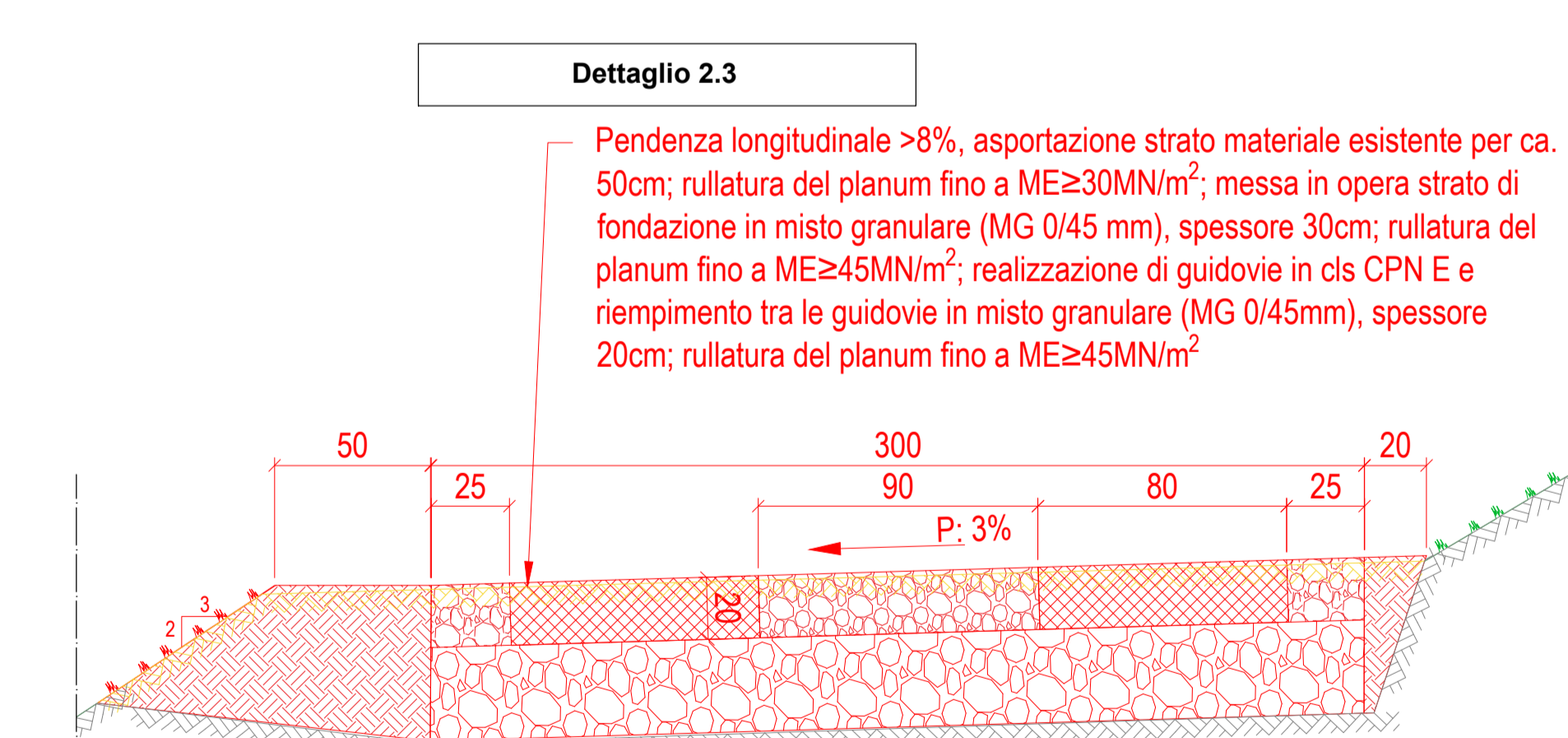
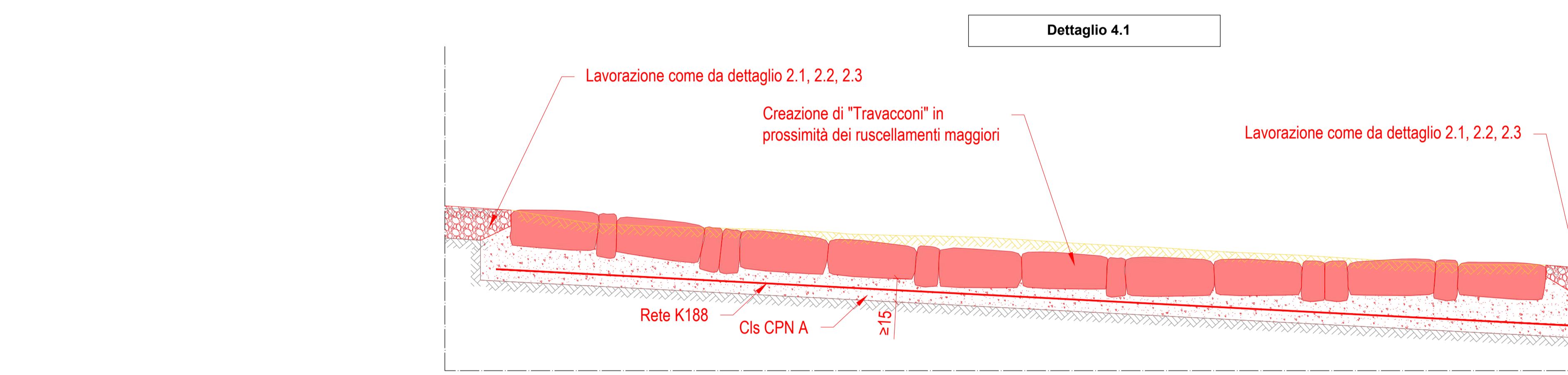
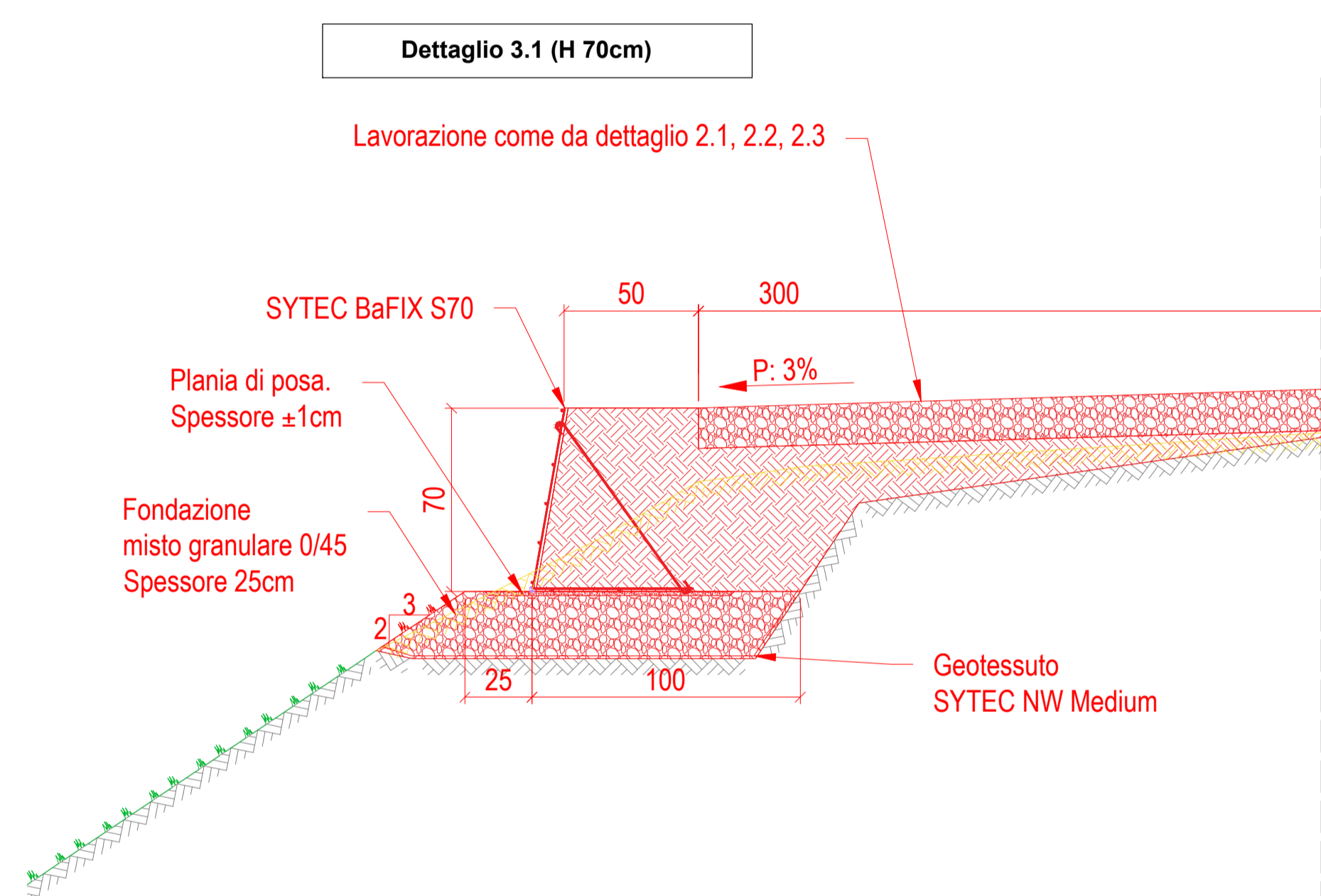
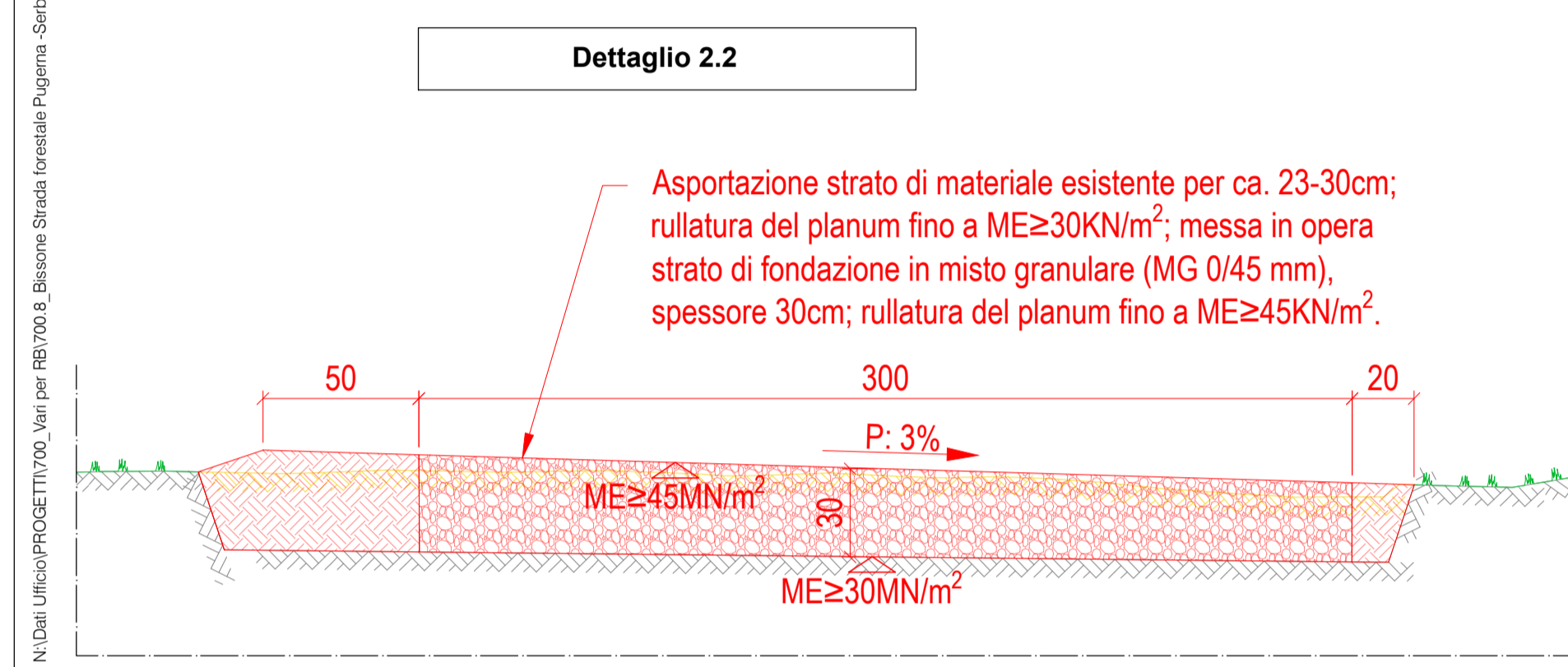
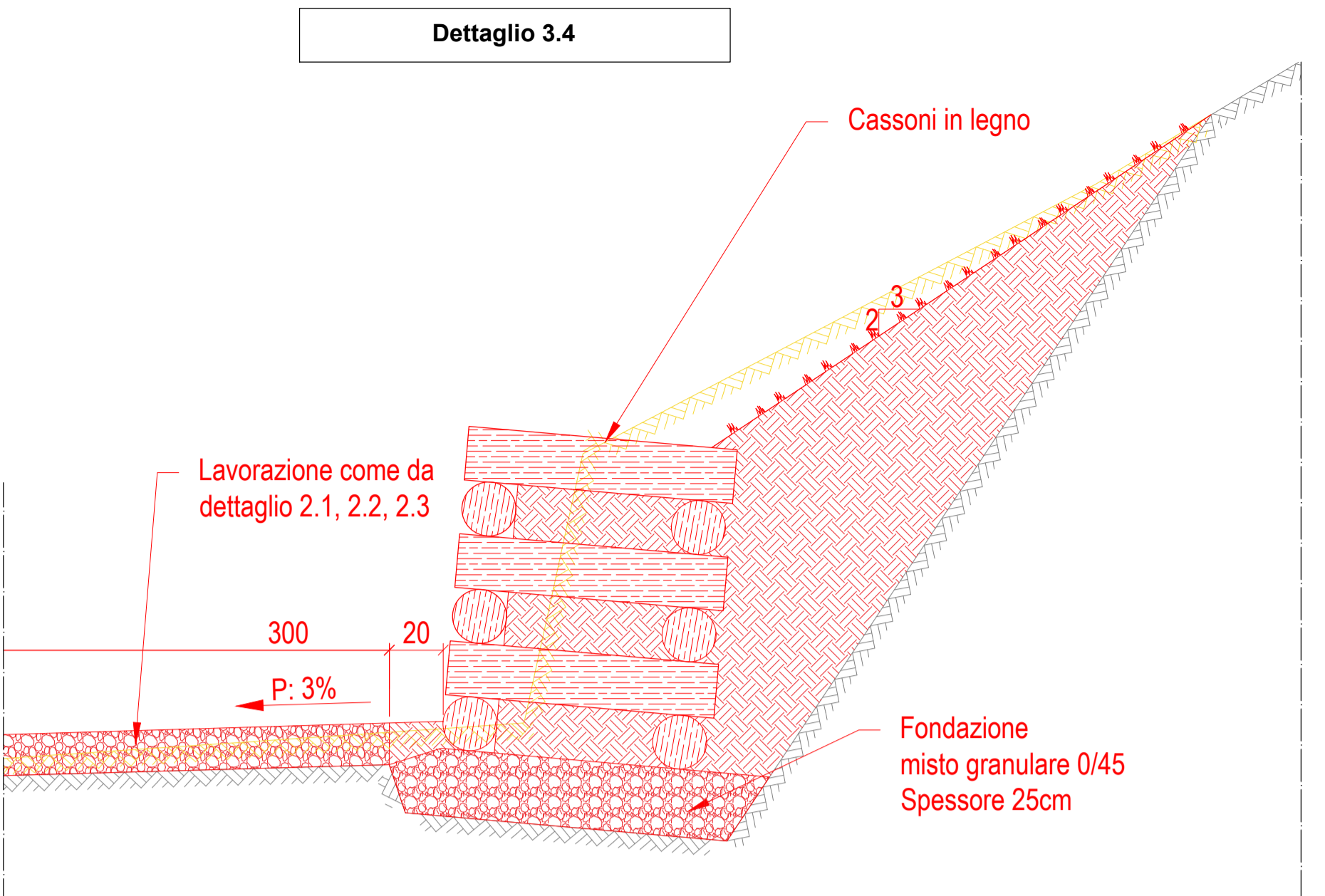
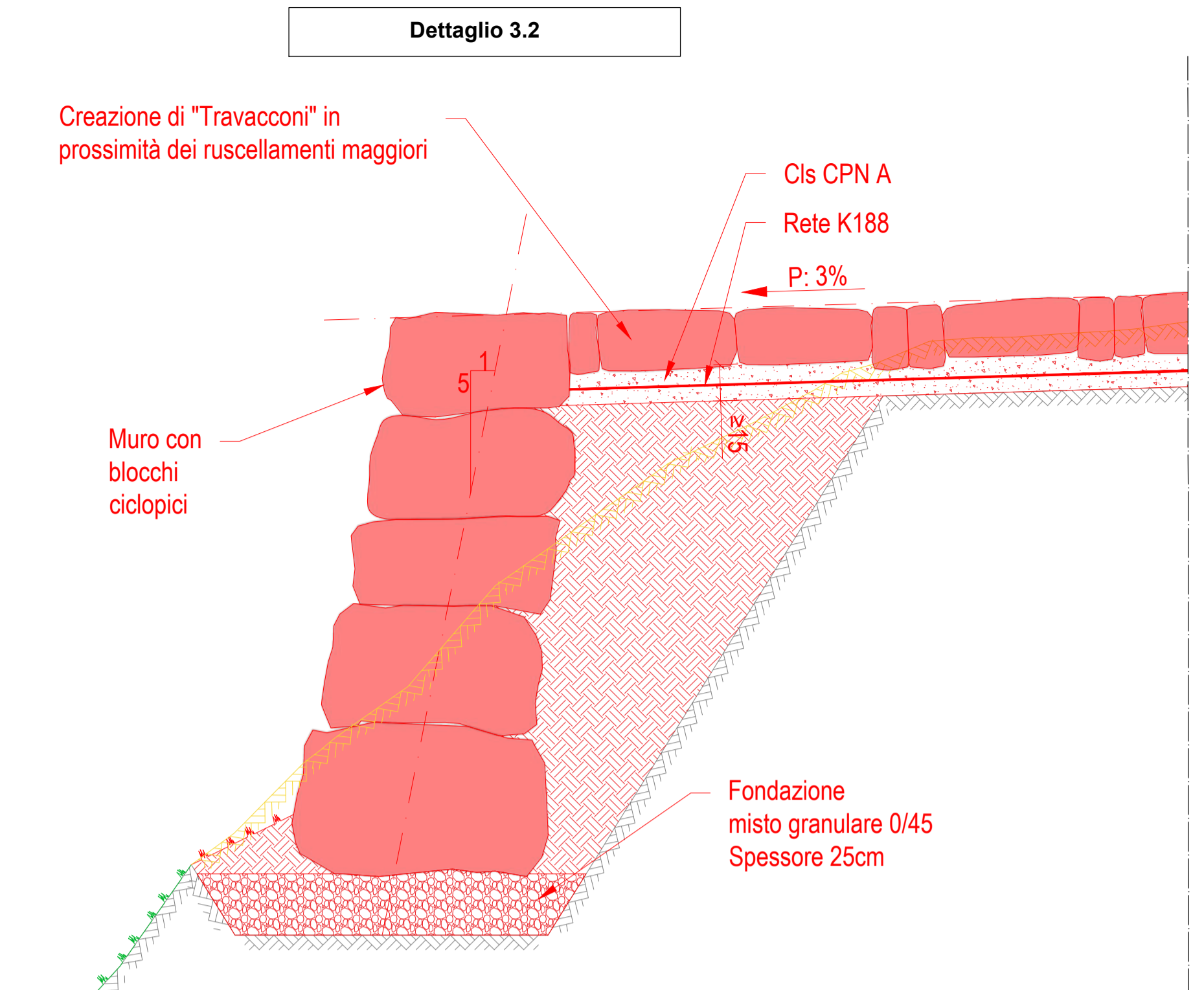
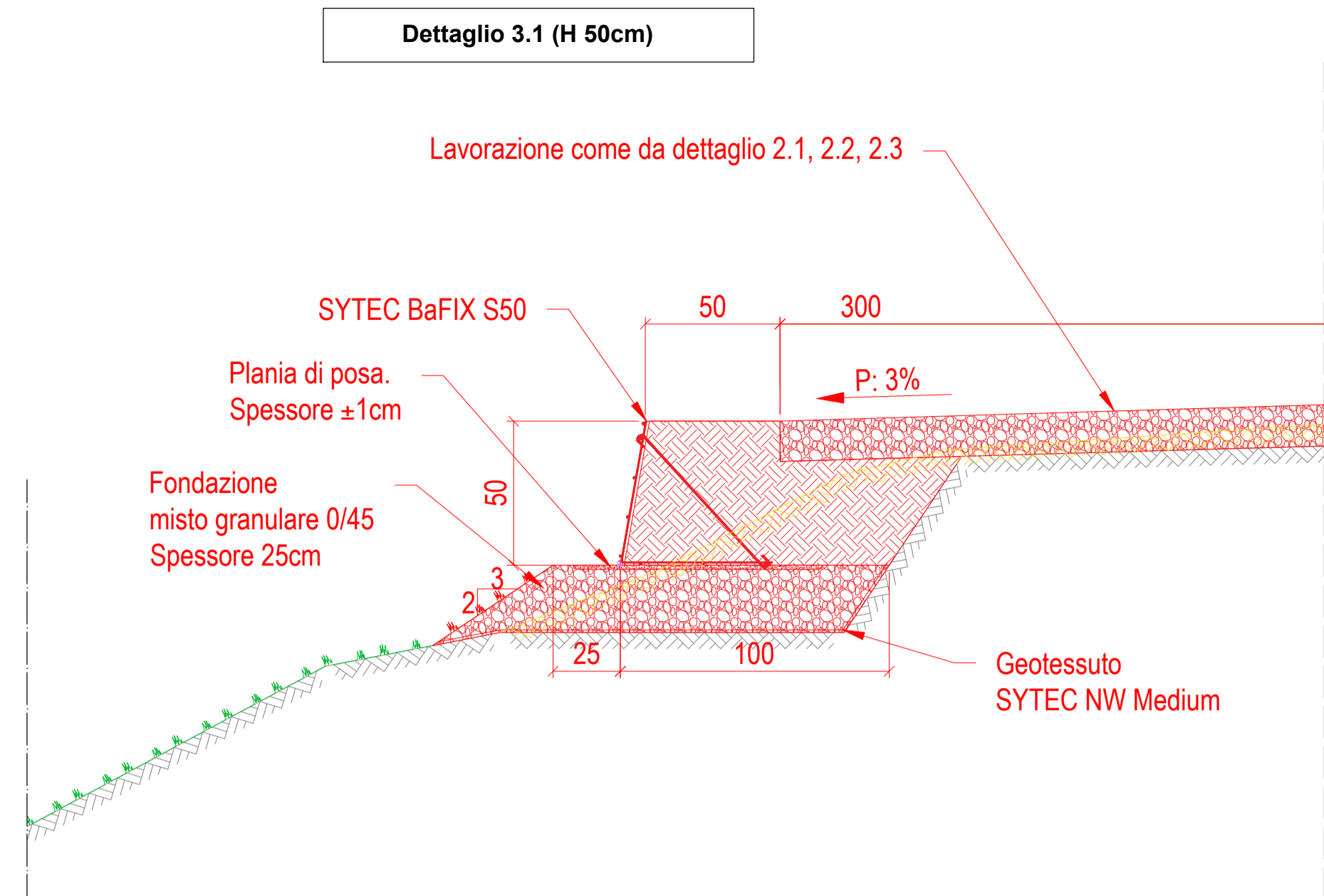
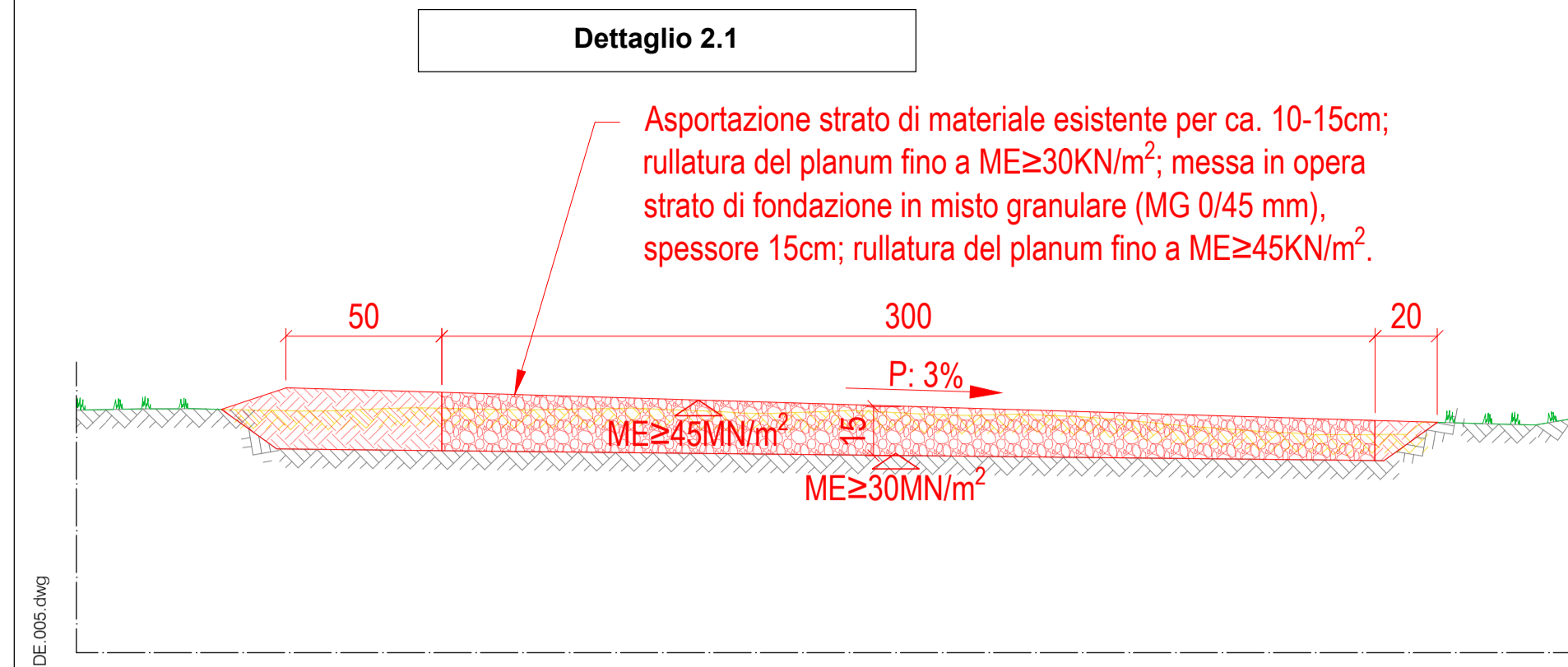

N:\Dati\Unico\PROGETTI\700_Via per Roncaglia\Bissone Strada forestale Roncaglia - Serbatoio\07 - Disegni\02 - PDE\Progetto definitivo\700.8.PDE.005.dwg

MODIFICHE			
ID	Data	Elab.	Modifiche
A			
B			
C			



PROGETTO DEFINITIVO

Sezioni caratteristiche 1:50

Piano no. : **700.8.PDE/ 006**

Data : 15.11.2024 Dimensioni : 1'050x600
Scala: 1:50

Modifiche :
A : _____ B : _____ C : _____

Allestito : POF Controllato : MR Approvato : FB



Studio d'Ingegneria
Fabio Bianchi & Associati SA

+41 (0)91 682 37 38 info@bianchi-ing.ch
Via Sottobio 26, Balerna Via ai Ròsc 17, Besazio



SAGL

+41 (0)91 994 26 00 info@bacciarini-ing.ch
Viale Stazione 7, Maroggia

Studi d'Ingegneria associati Ing. Civ. Dipl. ETHSIA/SVI/OTIA

N:\Data\Ufficio\PROGETTI\700_006\700_006_PDE\700_006_PDE_006.dwg

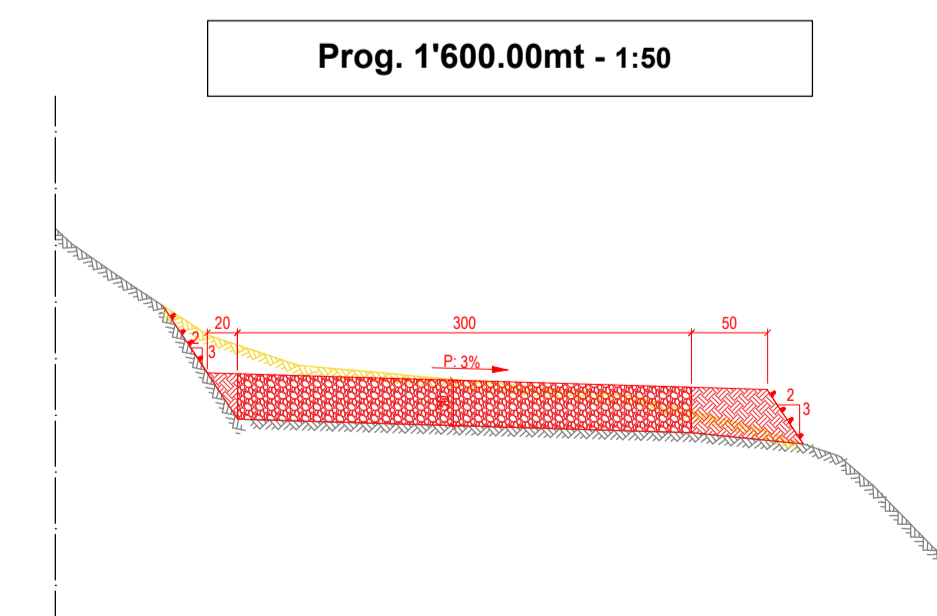
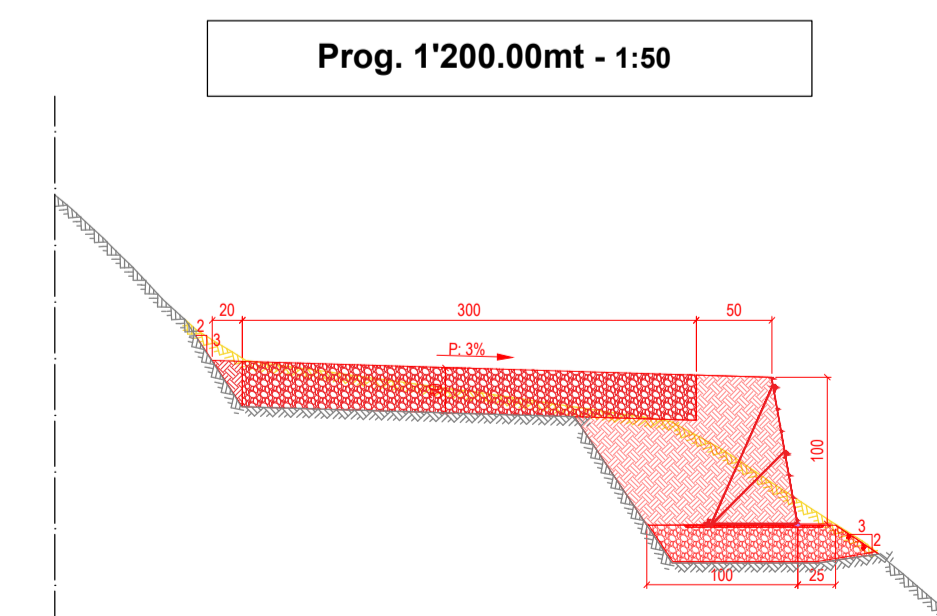
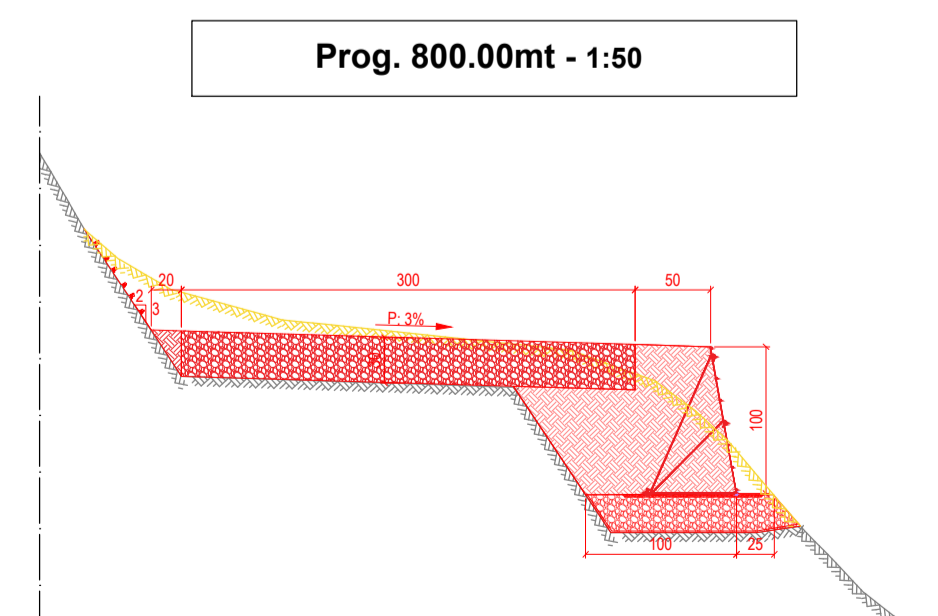
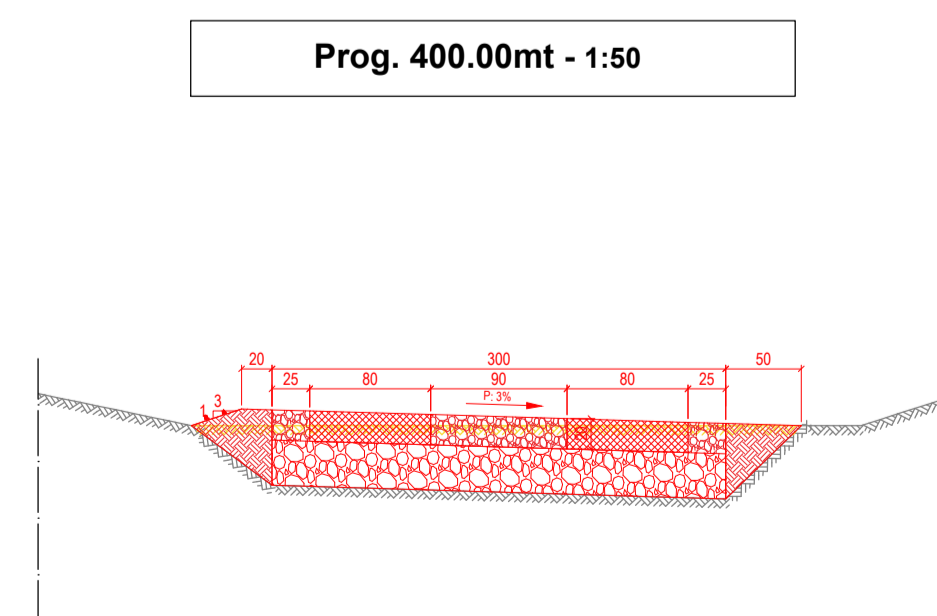
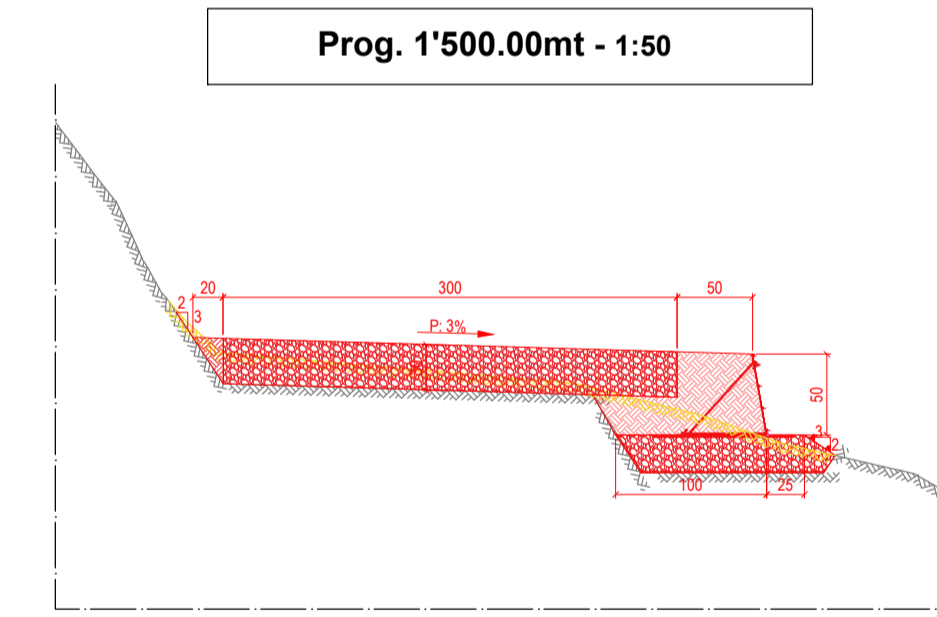
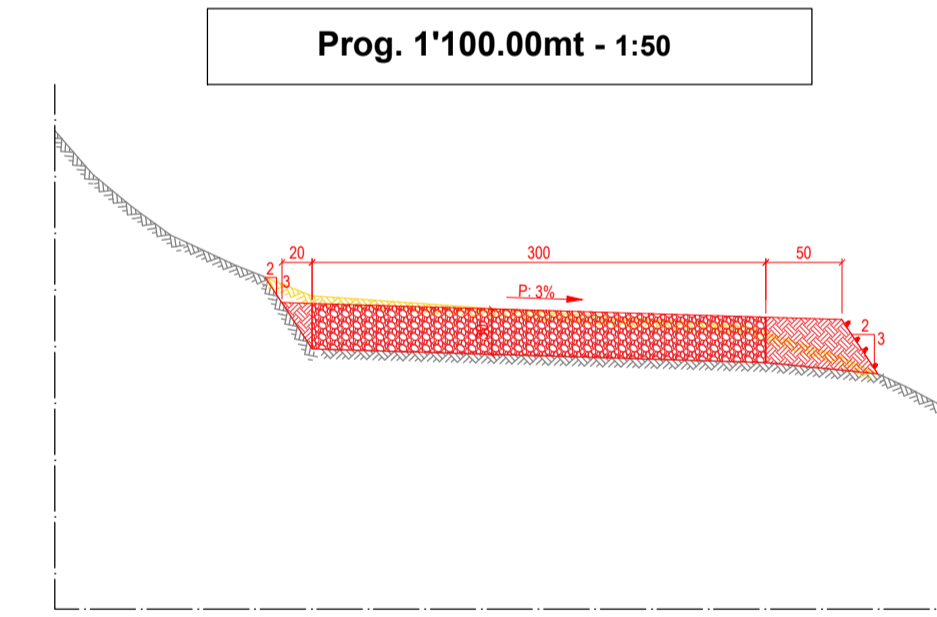
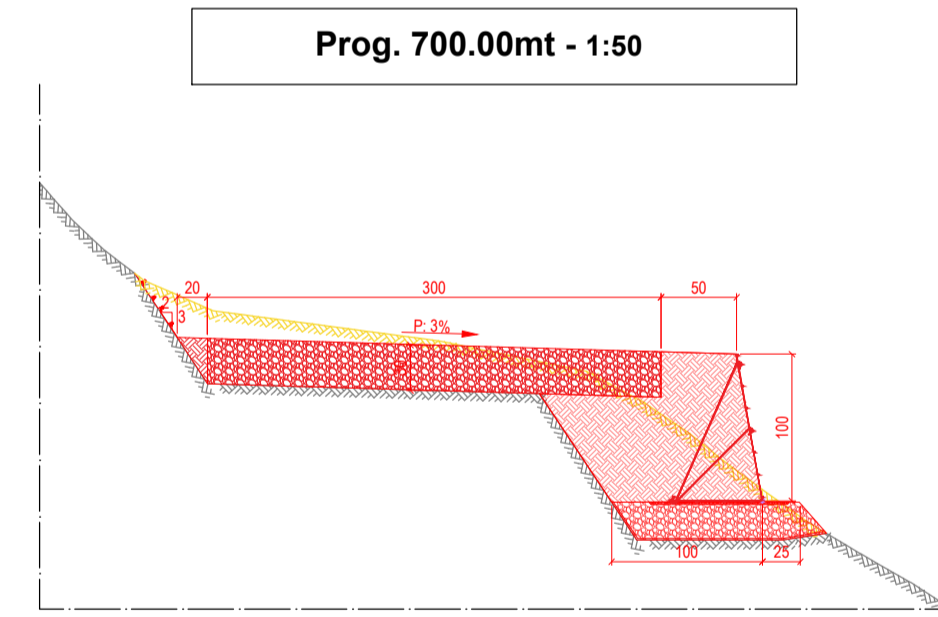
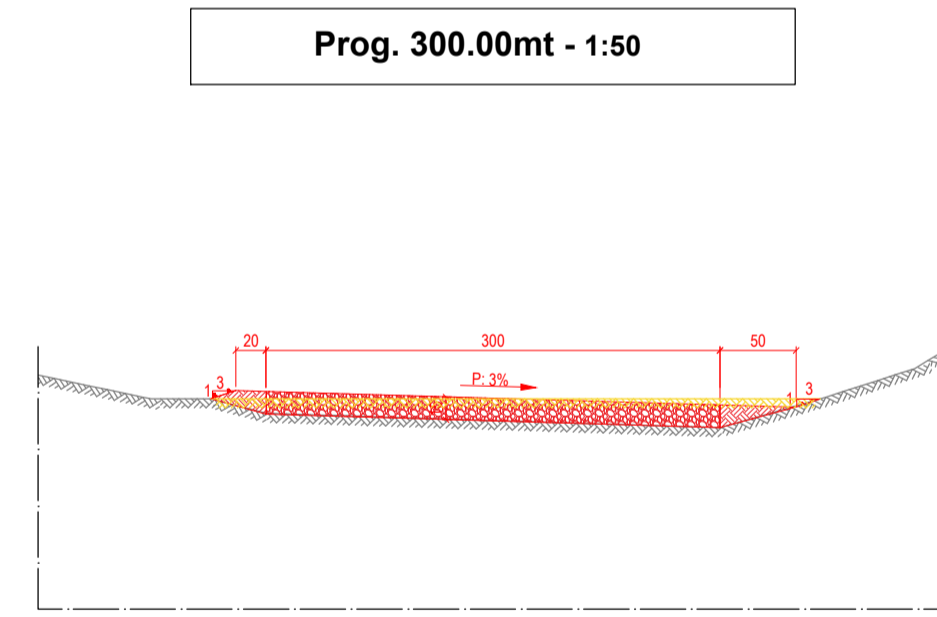
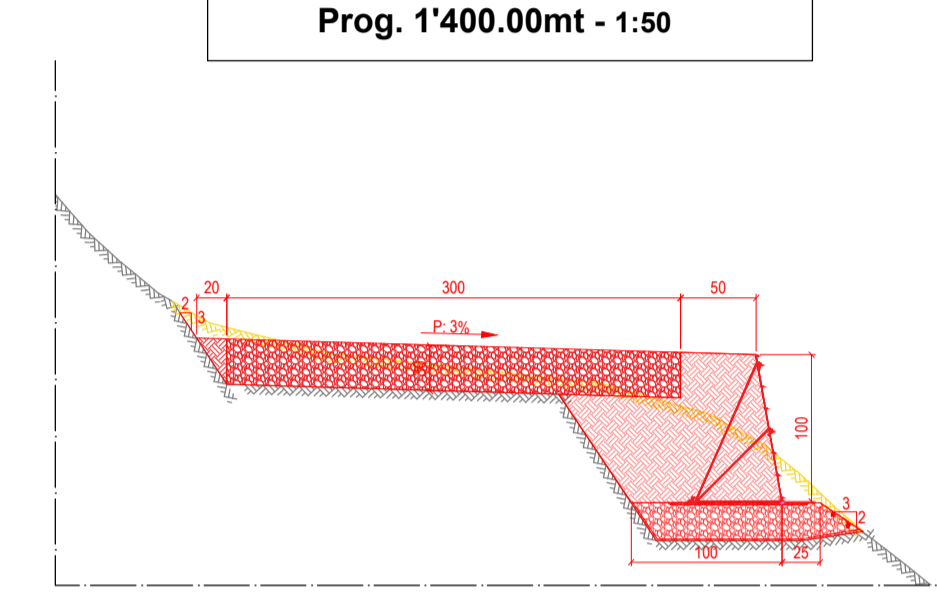
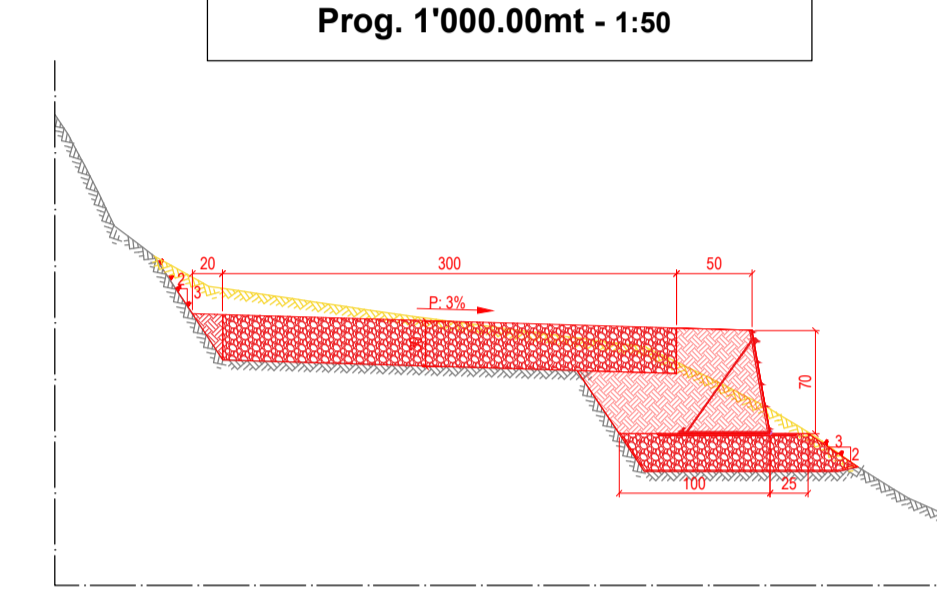
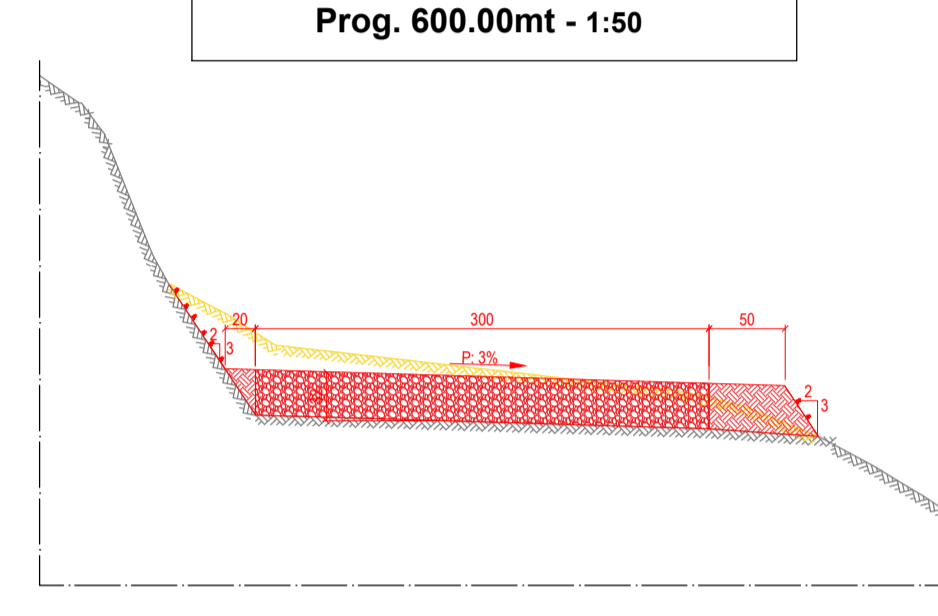
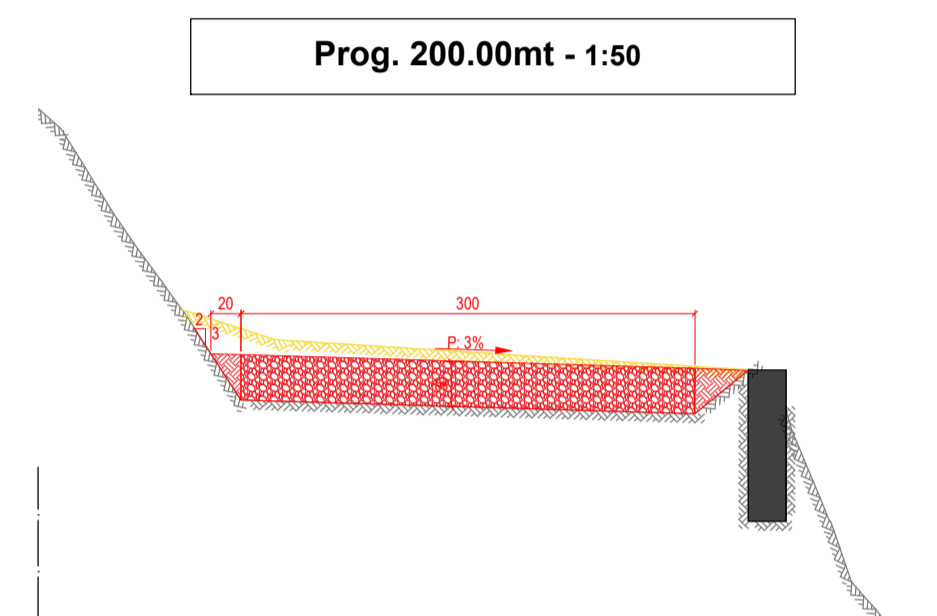
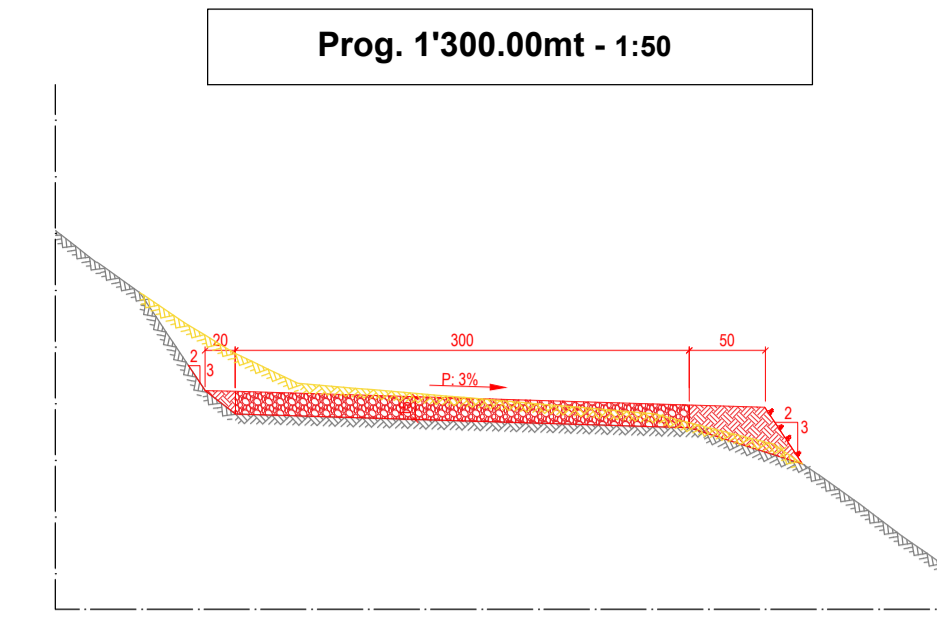
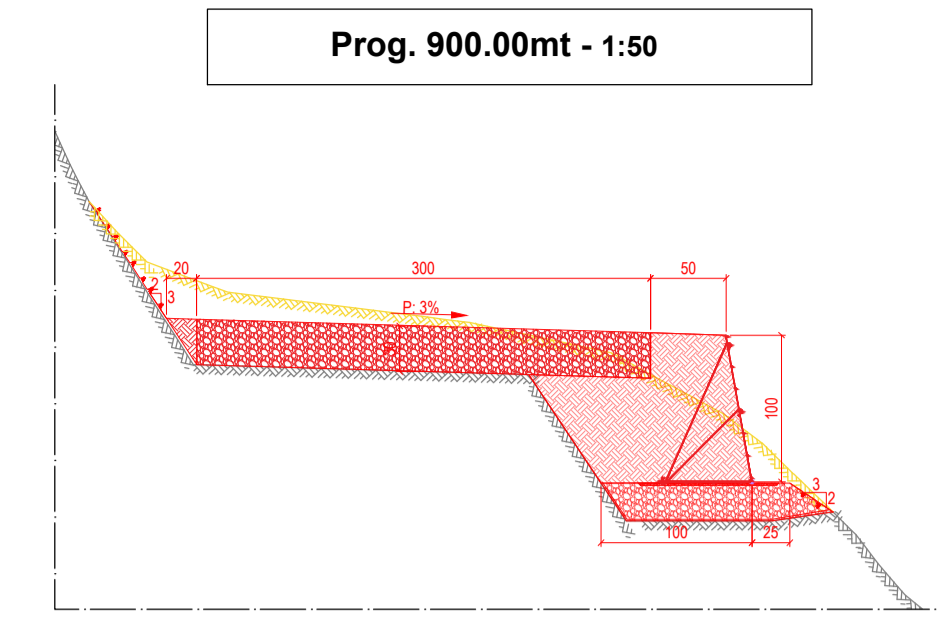
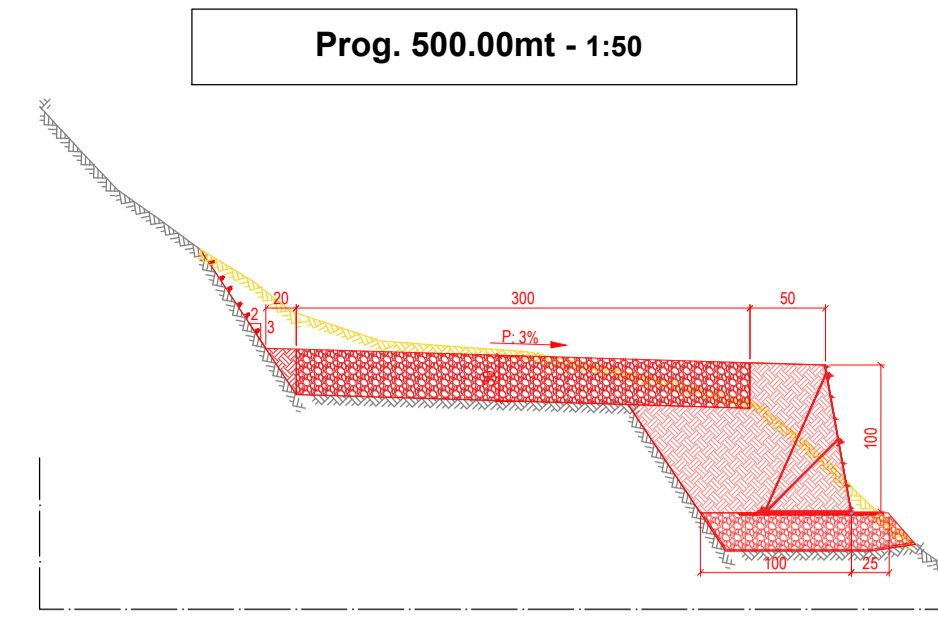
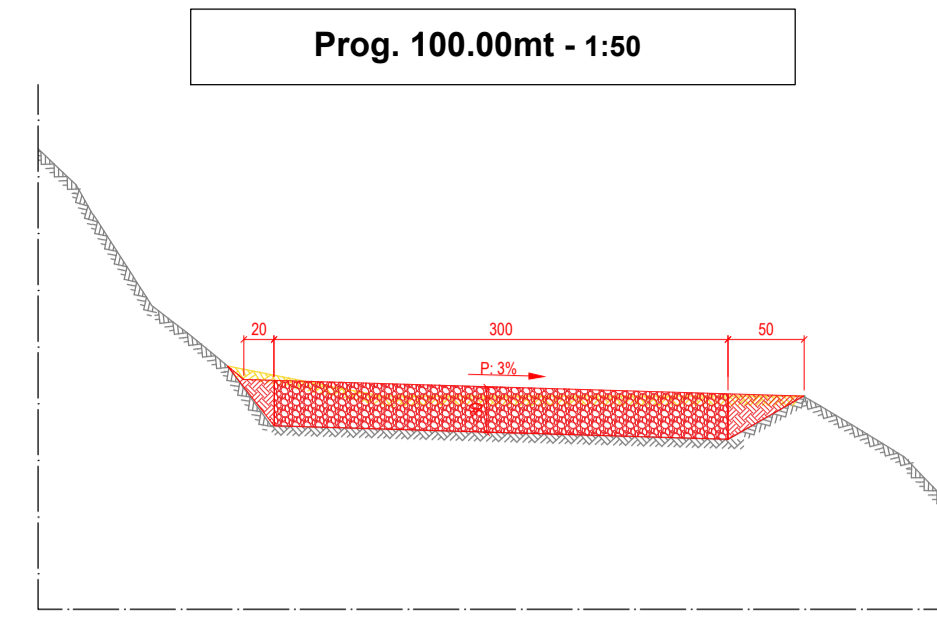

MODIFICHE:			
ID	Data	Elab.	Modifiche
A			
B			
C			



PROGETTO DEFINITIVO

Profilo longitudinale 1:2'000/500

Piano no. : **700.8.PDE/ 007**

Data : 15.11.2024 Dimensioni : 1'260x600
Scala: 1:2'000/500

Modifiche :
A : B : C :

Allestito : POF Controllato : MR Approvato : FB

Studi d'ingegneria associati Ing. Civ. Dipl. ETH/SIA/SVI/OTIA

N:\Dati\Unico\PROGETTI\700_Vari\08\700.8_Strada forestale Pugno Serbatoio07 - Disegno02 - PDE Progetto definitivo\700.8.PDE.007.dwg

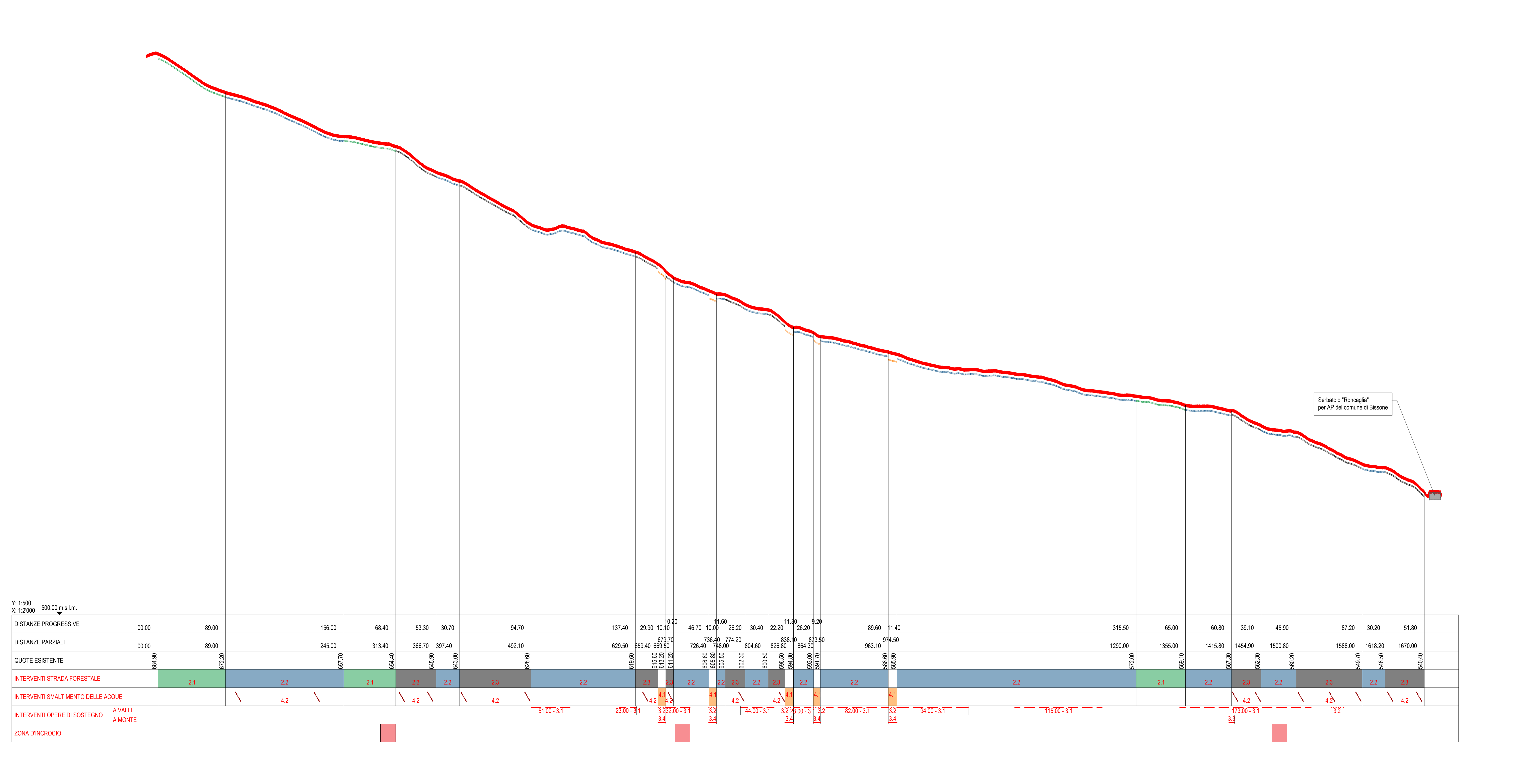

LEGENDA

- Strada forestale
- Pavimentazione miscela bituminosa
- Area intervento
- Ruscigliamento superficiale (0<h≤0.1 livello dell'acqua [m]) - www.geo.admin.ch

INTERVENTI PREVISTI

- Pulizia generale dei cigli da vegetazione ed alberi che restringono eccessivamente la carreggiata**
- Strada forestale:**
 - 2.1. Asportazione strato di materiale esistente per ca. 10-15cm; rullatura del planum fino a ME≥30MN/m²; messa in opera strato in misto granulare (MG 0/45 mm), spessore 15cm; rullatura del planum fino a ME≥45MN/m² (*).
 - 2.2 Asportazione strato di materiale esistente per ca. 25-30cm; rullatura del planum fino a ME≥30MN/m²; messa in opera strato in misto granulare (MG 0/45 mm), spessore 30cm; rullatura del planum fino a ME≥45MN/m² (*).
 - 2.3 Pendenza longitudinale >8%, asportazione strato materiale esistente per ca. 50cm; rullatura del planum fino a ME≥30MN/m²; messa in opera strato di fondazione in misto granulare (MG 0/45 mm), spessore 30cm; rullatura del planum fino a ME≥45MN/m²; realizzazione di guidovie in cls CPN E e riempimento tra le guidovie in misto granulare (MG 0/45mm), spessore 20cm; rullatura del planum fino a ME≥45MN/m² (*).

(*) Dimensioni di progetto tratti con allargamento: banchina a monte 0,20mt, larghezza strada 3mt, banchina a valle 0,50mt.

- Opere di sostegno**
 - 3.1 Rinforzo del bordo stradale sottoscarpa con reti d'acciaio tipo "Sytec BaFix", H= ca. 0.5 m / 1.0 m
 - 3.2 Rinforzo del bordo stradale sottoscarpa con muro con blocchi ciclopici
 - 3.3 Rinforzo del bordo stradale controripa con muro con blocchi ciclopici
 - 3.4 Rinforzo del bordo stradale controripa con muro con cassoni in legno
- Smaltimento delle acque**
 - 4.1 Nuovo travaccone
 - 4.2 Canalette trasversali per lo smaltimento acque (pendenze long. >8%)

MODIFICHE			
ID	Data	Elab.	Modifiche
A			
B			
C			

PROGETTO DEFINITIVO

Acquisizione fondi e diritti 1:1'000

Piano no. : **700.8.PDE/008**

Data : 15.11.2024 Dimensioni : 1'680x450
Scala: 1:1'000

Modifiche:
A: B: C:

Allestito : POF Controllato : MR Approvato : FB



Studi d'ingegneria associati Ing. Civ. Dipl. ETH/SIA/SVI/OTIA

LEGENDA

- Strada forestale
- Pavimentazione miscela bituminosa
- Area intervento

ID	Data	Elab.	Modifiche
A			
B			
C			



Particella n°.	Occ. Definitiva	Occ. Temp.
Mappale 870	m² 1217.15	m² 152.25

Particella n°.	Occ. Definitiva	Occ. Temp.
Mappale 302	m² 860.00	m² 528.45

Particella n°.	Occ. Definitiva	Occ. Temp.
Mappale 785	m² 154.60	m² 58.30

Particella n°.	Occ. Definitiva	Occ. Temp.
Mappale 239	m² 101.65	m² 45.60

Particella n°.	Occ. Definitiva	Occ. Temp.
Mappale 338	m² 220.35	m² 118.50

Particella n°.	Occ. Definitiva	Occ. Temp.
Mappale 310	m² 110.25	m² 65.25

Particella n°.	Occ. Definitiva	Occ. Temp.
Mappale 332	m² 165.30	m² 89.25

Particella n°.	Occ. Definitiva	Occ. Temp.
Mappale 326	m² 190.65	m² 105.45

Particella n°.	Occ. Definitiva	Occ. Temp.
Mappale 325	m² 150.30	m² 81.65

Particella n°.	Occ. Definitiva	Occ. Temp.
Mappale 323	m² 60.80	m² 27.80

Particella n°.	Occ. Definitiva	Occ. Temp.
Mappale 634	m² 13.10	m² 10.20

Particella n°.	Occ. Definitiva	Occ. Temp.
Mappale 328	m² 175.60	m² 95.15

Particella n°.	Occ. Definitiva	Occ. Temp.
Mappale 335	m² 351.80	m² 188.30

Particella n°.	Occ. Definitiva	Occ. Temp.
Mappale 336	m² 52.15	m² 37.30

Particella n°.	Occ. Definitiva	Occ. Temp.
Mappale 694	m² 374.60	m² 173.95

Particella n°.	Occ. Definitiva	Occ. Temp.
Mappale 337	m² 9.30	m² 81.20

Particella n°.	Occ. Definitiva	Occ. Temp.
Mappale 635	m² 197.25	m² 149.90

Particella n°.	Occ. Definitiva	Occ. Temp.
Mappale 402	m² 173.95	m² 130.00

Particella n°.	Occ. Definitiva	Occ. Temp.
Mappale 405	m² 120.10	m² 63.10

Particella n°.	Occ. Definitiva	Occ. Temp.
Mappale 642	m² 35.90	m² 16.00

Particella n°.	Occ. Definitiva	Occ. Temp.
Mappale 411	m² 114.80	m² 60.95

Particella n°.	Occ. Definitiva	Occ. Temp.
Mappale 413	m² 219.70	m² 115.70

Particella n°.	Occ. Definitiva	Occ. Temp.
Mappale 403	m² 257.40	m² 153.15

Particella n°.	Occ. Definitiva	Occ. Temp.
Mappale 406	m² 118.70	m² 63.90

Particella n°.	Occ. Definitiva	Occ. Temp.
Mappale 412	m² 229.65	m² 116.00

PROGETTO DEFINITIVO

Fasi d'intervento 1:1'000

Piano no. : **700.8.PDE/ 009**

Data : 15.11.2024
Dimensioni : 1'890x450
Scala: 1:1'000

Modifiche :
A : B : C :

Allestito : POF
Controllato : MR
Approvato : FB



Studi d'ingegneria associati Ing. Civ. Dipl. ETH/SIA/SV/OTIA

LEGENDA

- Strada forestale
- Pavimentazione miscela bituminosa
- Area intervento
- Ruscigliamento superficiale (0<h≤0.1 livello dell'acqua [m]) - www.geo.admin.ch

ID	Data	Elab.	Modifiche
A			
B			
C			



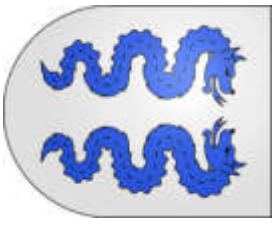

Arognò zona S. Vitale / Bissone zona Roncaglia

**Strada forestale San Vitale/
Serbatoio Roncaglia**

PROGETTO DEFINITIVO

Planimetria infrastrutture esistenti e di progetto 1:2'000

Piano no. : **700.8.PDE/010**

Data : 15.11.2024

Dimensioni : 1260x300
Scala : 1:2'000

Modifiche :

A : B : C :

Allestito : POF Controllo : MR Approvato : FB



Fabio Bianchi & Associati SA

Studio d'ingegneria

4+1 (0)91 632 37 28 info@bianchi-hatch
Via Sottosasso 26 Salerna Via al Nos 17, Assiso

4+1 (0)91 994 26 00 info@bucchinling.ch
Viale Stazione 7, Maroggia

N:\Dati Ufficio\PROGETTI\700_Vari per RB\700.8_Bissone Strada forestale Pugerna -Serbatoio\07 - Disegni\02 - PDE Progetto definitivo\700.8.PDE.010.dwg

INFRASTRUTTURE

CANALIZZAZIONI PUBBLICHE:

- Comunali acque luride
- Comunali acque miste
- Comunali acque meteoriche
- Comunali caditoie stradali

CANALIZZAZIONI PUBBLICHE:

- Consortili acque miste

TELEFONIA E RETI DATI:

- Swisscom SA
- Pozzetti / Camere
- Sunrise
- Pozzetti / Camere

ACQUEDOTTO COMUNALE:

- Condotte
- Saracinesche
- Idranti
- Camere

RETE ELETTRICA (ALL SA):

- Cavidotti
- Linea aerea
- Camere e pozzetti
- Candelabri illuminazione pubblica

- Asse tracciato esistente
- Area d'intervento

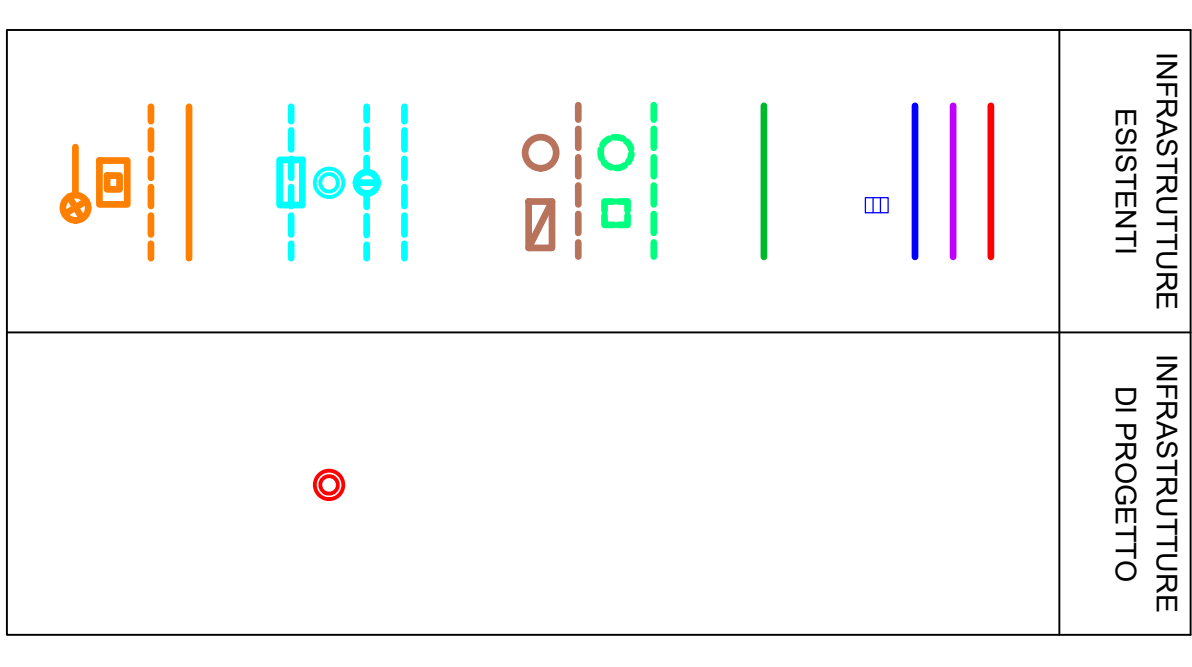

MODIFICHE:			
ID	Data	Elab.	Modifiche
A			
B			
C			

PLANIMETRIA - 1:2'000

